

Elevation

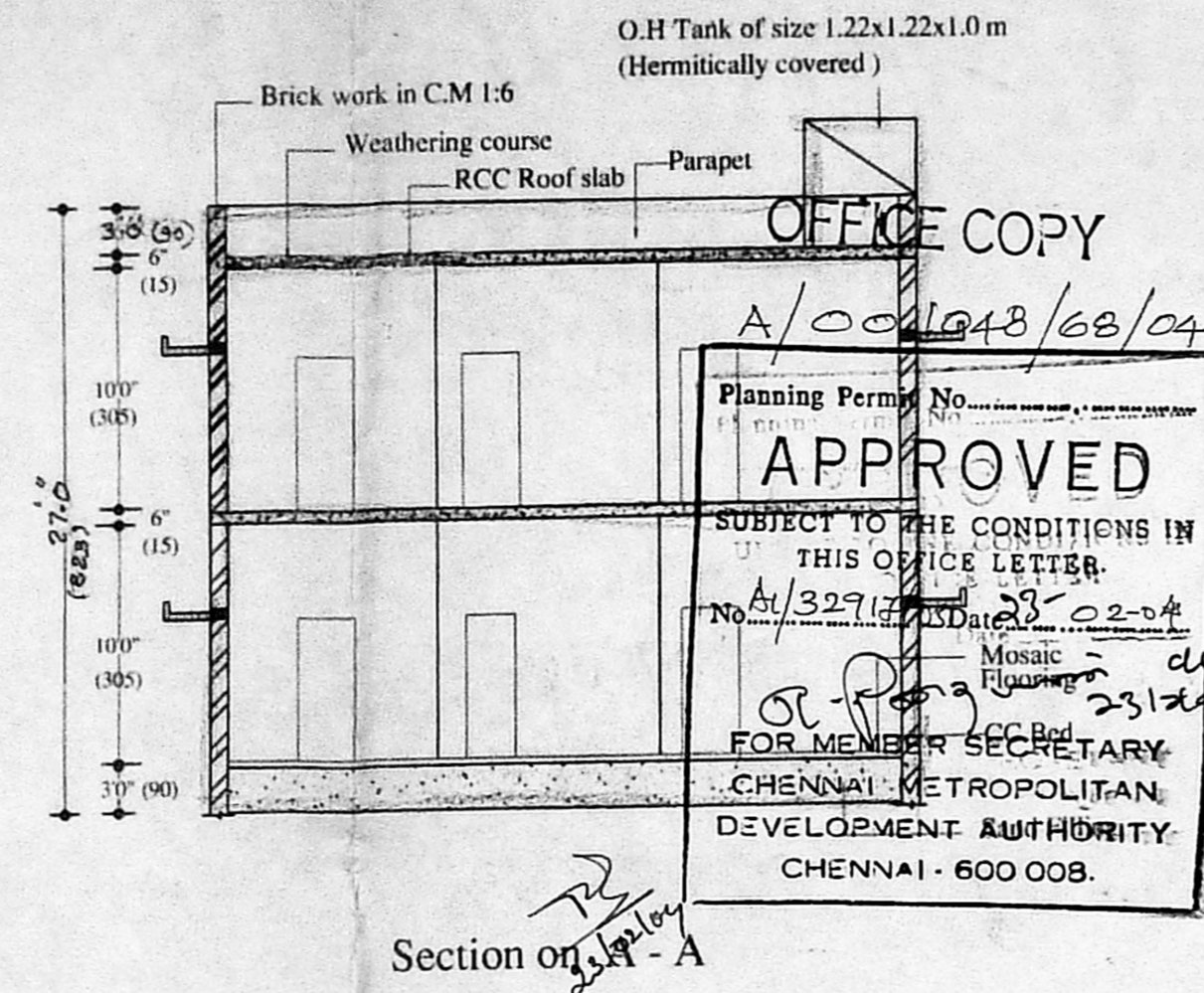

Section on A-A

O.H Tank of size 1.22x1.22x1.0 m
(Hermitically covered)

OFFICE COPY
A/0001948/68/04
Planning Permission No. A/32913/23-02-04
APPROVED
SUBJECT TO THE CONDITIONS IN THIS OFFICE LETTER.
FOR MEMBER SECRETARY
CHENNAI METROPOLITAN
DEVELOPMENT AUTHORITY
CHENNAI - 600 008.

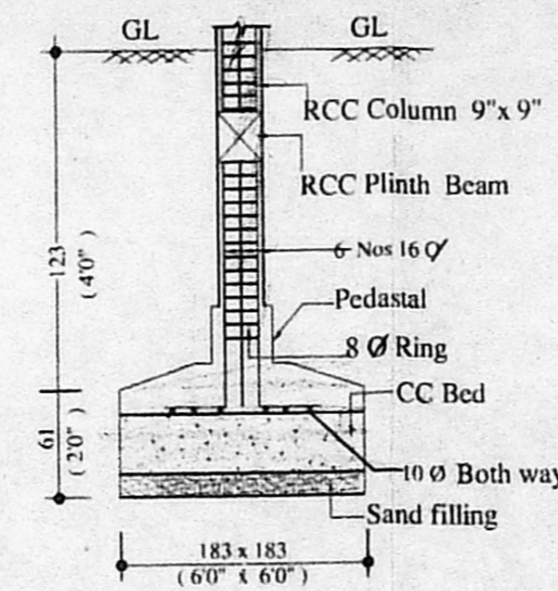

Details of Foundation

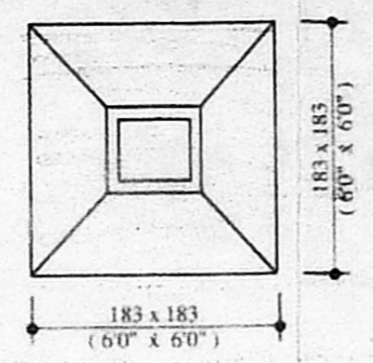

Plan

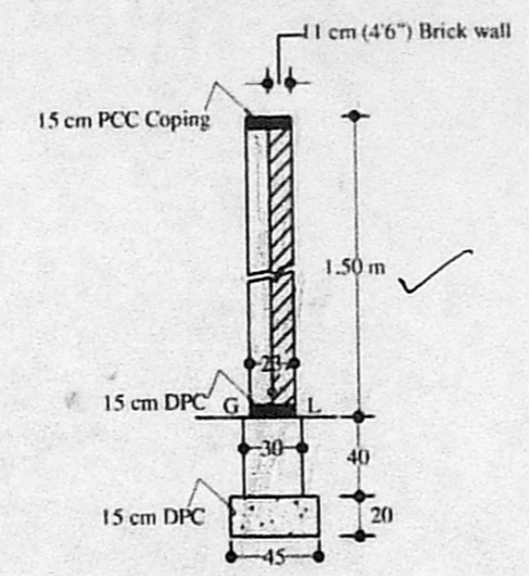

Section Of Compound Wall

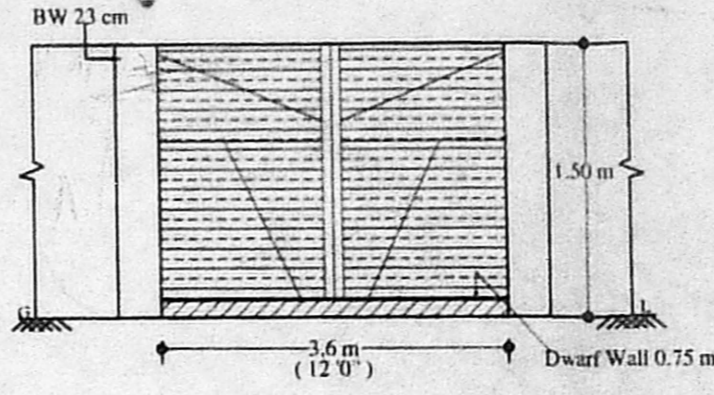

Elevation of Gate

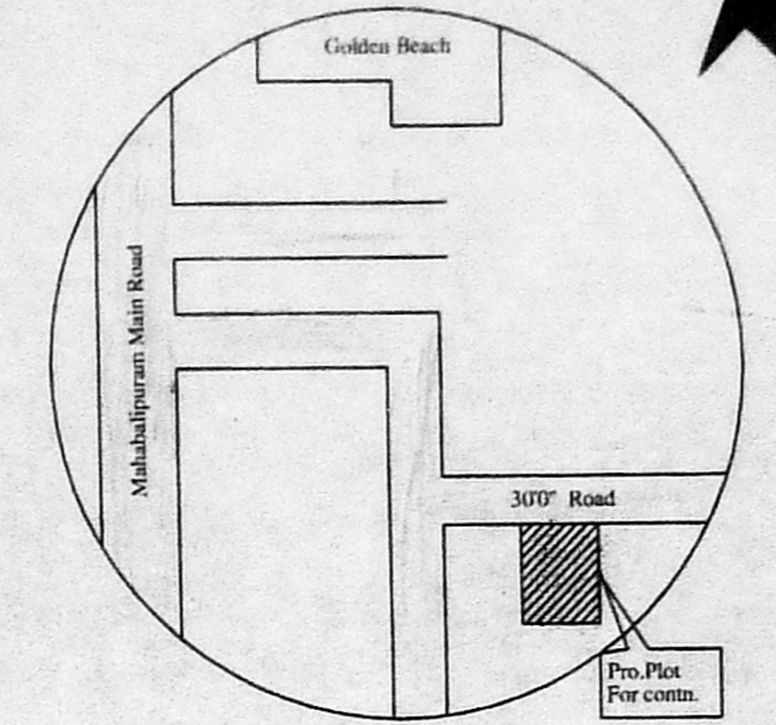

Key Plan
N.T.S



PLAN SHOWING "A" CHANNEL
PROPOSED CONSTRUCTION OF
GROUND FLOOR AND FIRST FLOOR AT PLOT No. 539
SURVEY No: 372 B 1, 191,
UTHANDI VILLAGE, UTHANDI,
TAMBARAM TALUK
KANCHEEPURAM DIST.

SCALE 1:100 (OR) 1/8" = 1'0"

DETAILS OF JOINERY

D Door	40"X70"	(1200X210)
D1 Door	30"X60"	(900X180)
D2 Door	20"X60"	(60X180)
W Window	4'6"X4'0"	(135X120)
W1 Window	3'0"X4'0"	(135X120)
V Ventilator	2'0"X1'0"	(60X30)
J Jolly	5'0"X10'0"	(1530 X 3050)

AREA DETAILS

	sq.ft	sq.m
Total Plot Area :	2400	223
Builtup Area :		
Ground Floor :	990	92
First Floor :	990	92
Proposals shown :		
Roads shown :		
Coverage :	41 %	
F.S.I :	0.82	

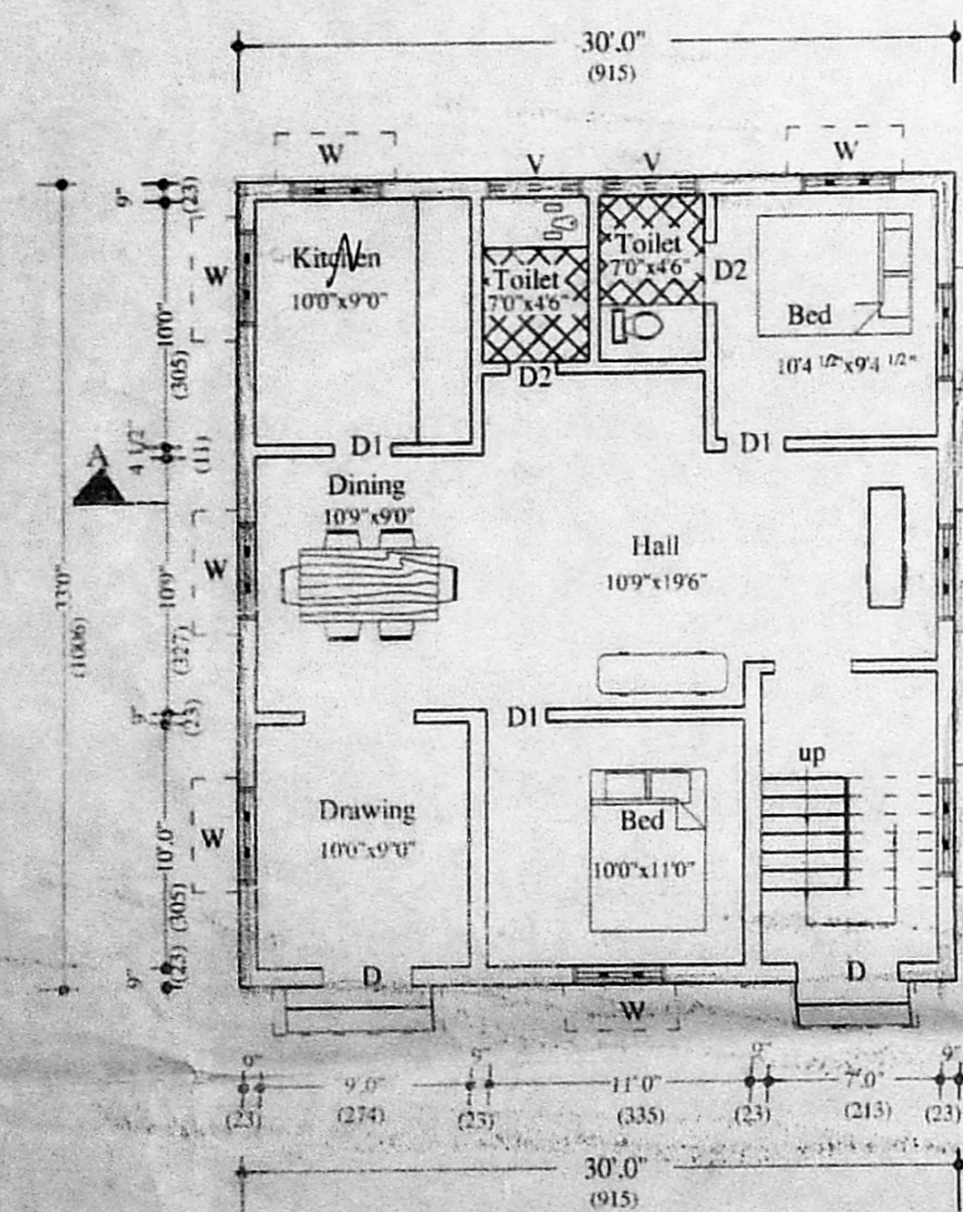

Plan of Ground Floor

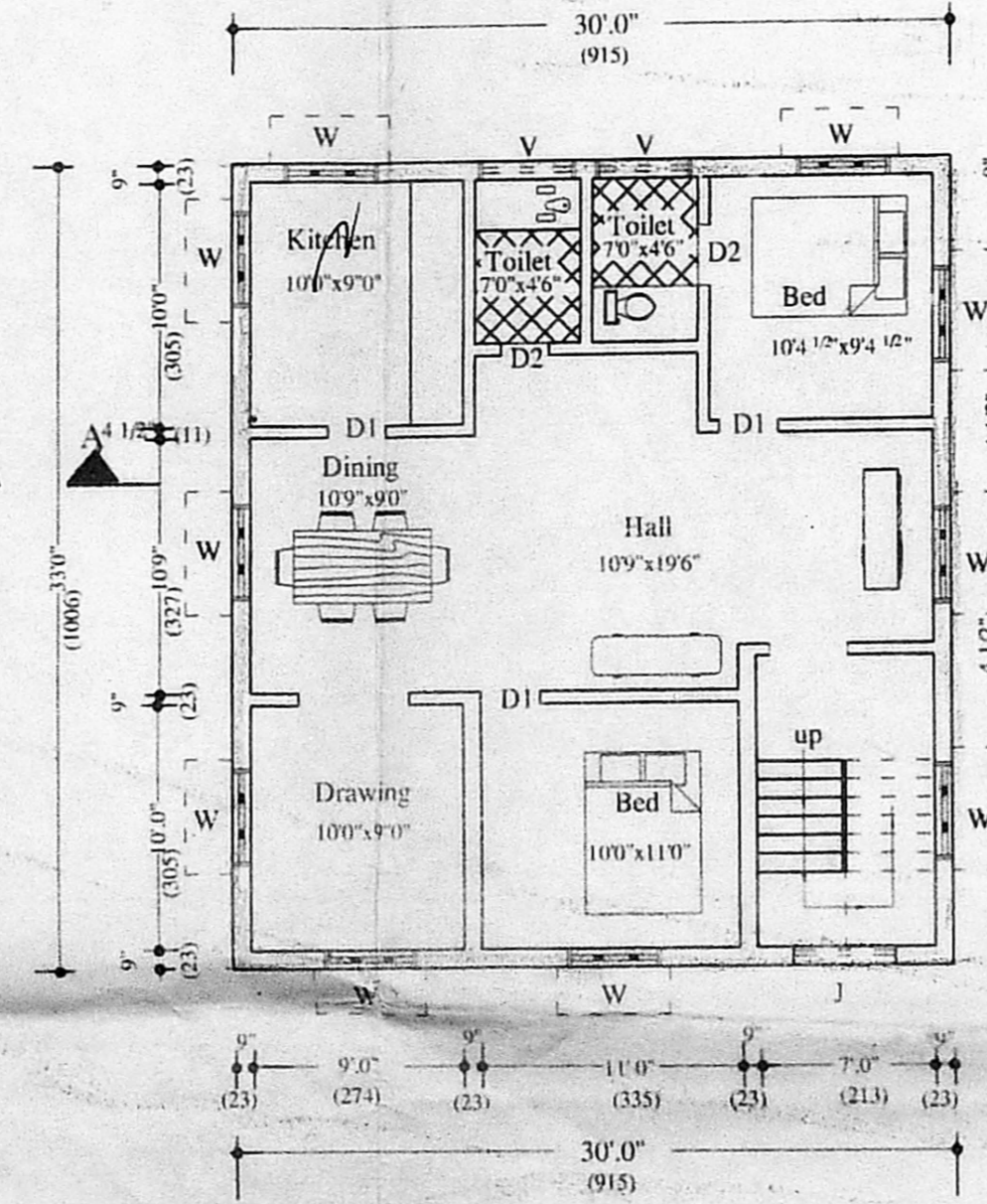

Plan of First Floor

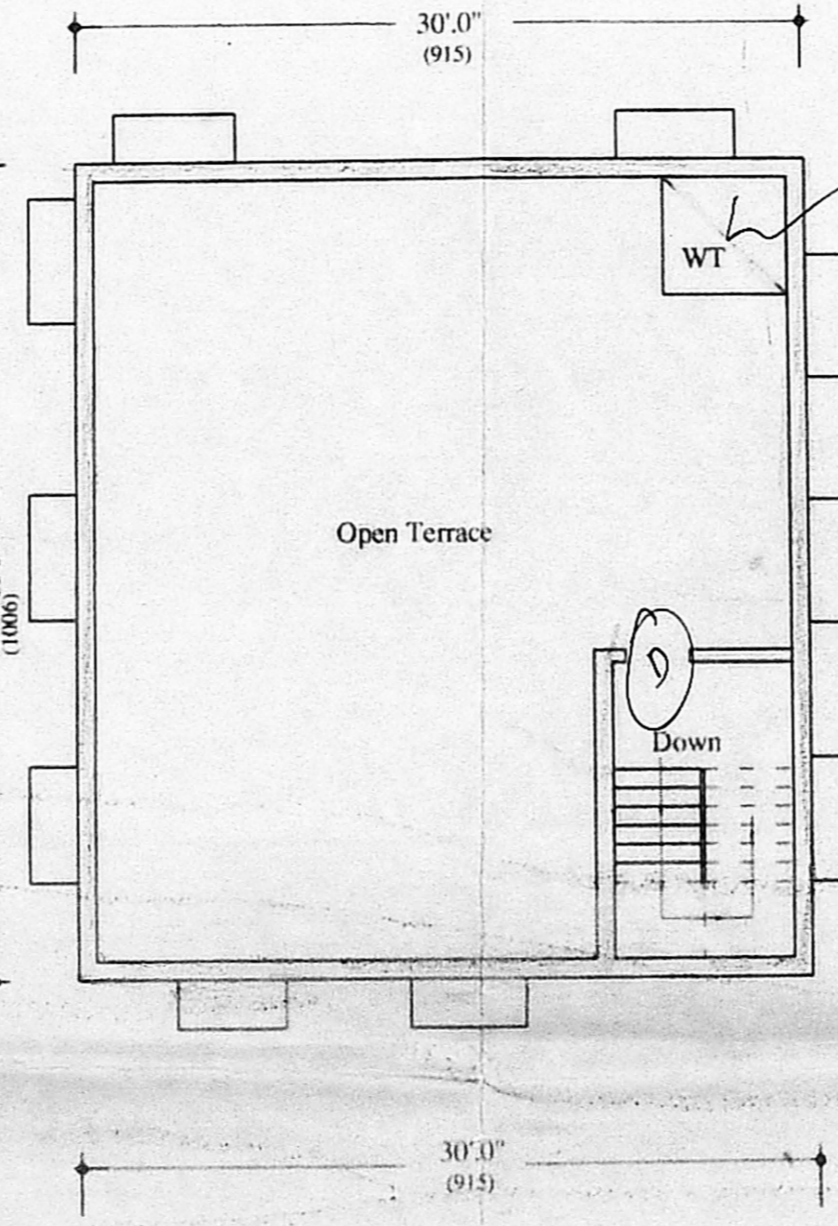

Plan of Open Terrace

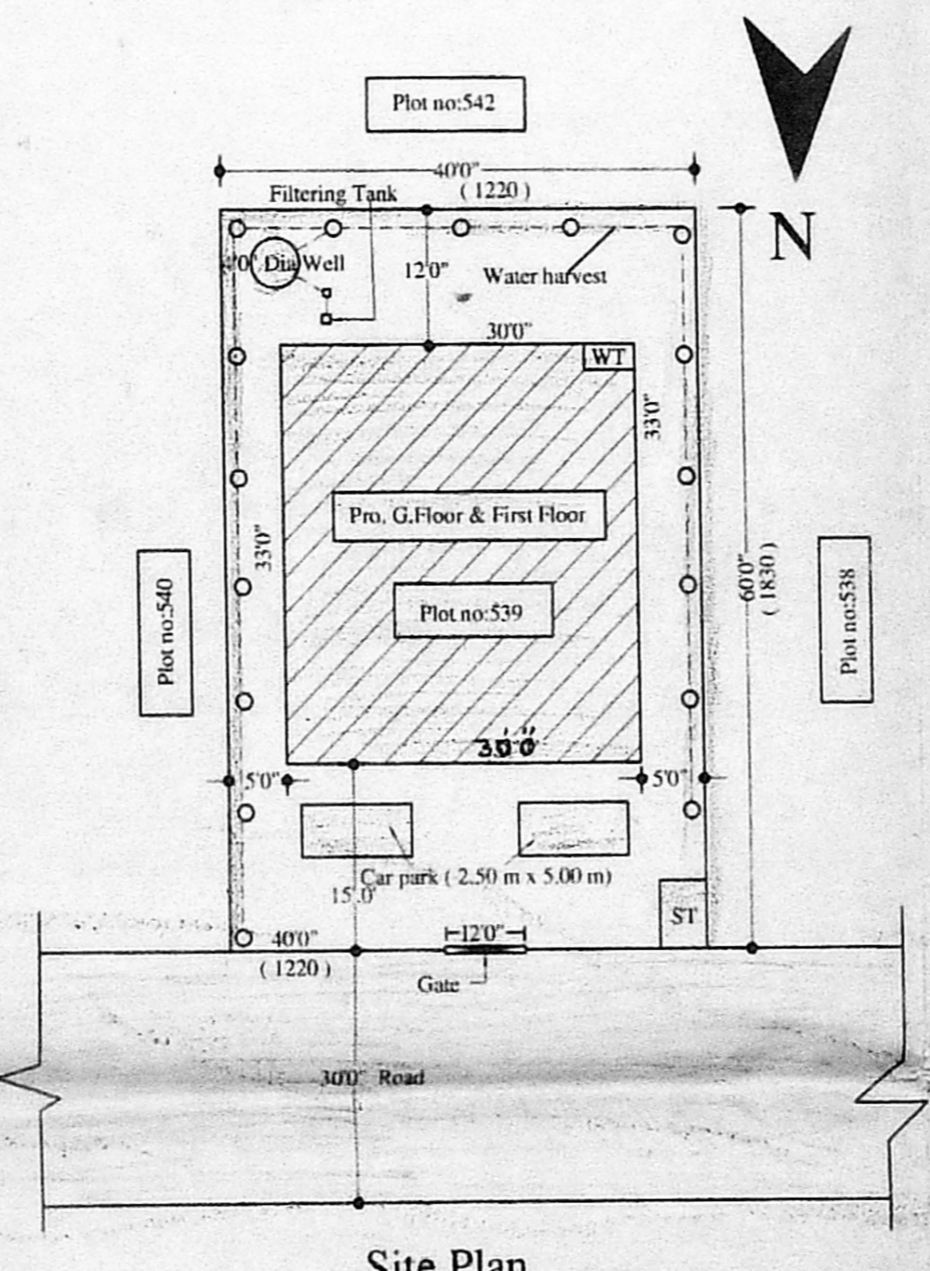

Site Plan
Scale 1:200

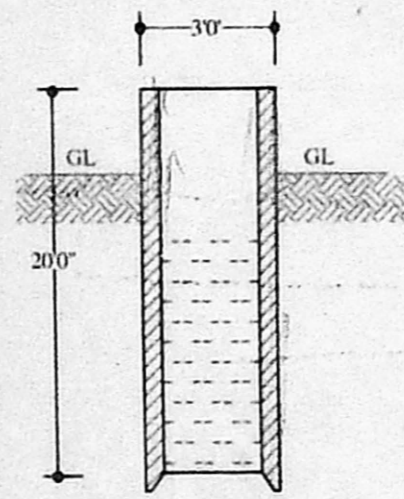

Details of Well

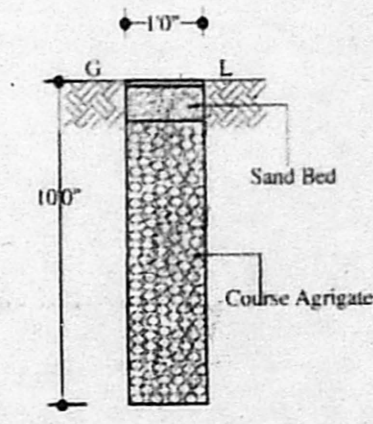

Percolation pit

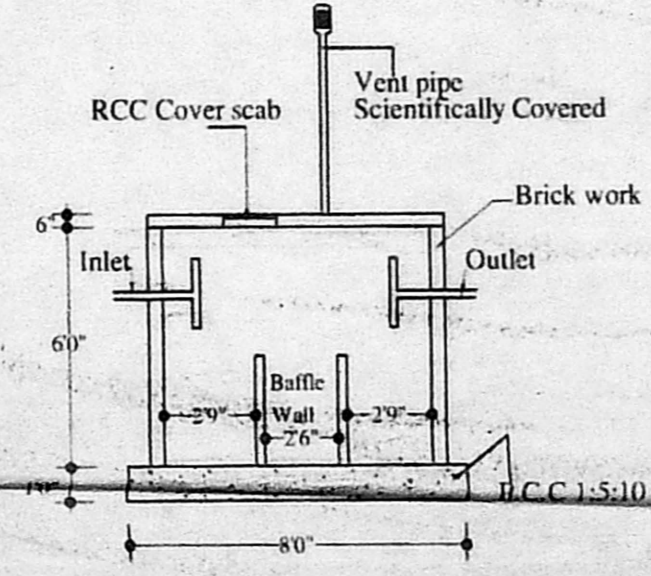

Details Of Septic Tank

Aravinth
A.R. - RAVIN THEKA MATHI
Name of owner

T. LANTEN
Consulting Civil Engineer,
Licensed Surveyor - Class-II No.496
Corporation of Chennai
No.31/11, Masley Second St.,
T. Nagar, Chennai - 17. ☎: 4335887
Licesed surveyor